



MAULANA ABUL KALAM AZAD UNIVERSITY OF TECHNOLOGY, WEST BENGAL

Paper Code : EC402 Analog Electronic Circuits

UPID : 004452

Time Allotted : 3 Hours

Full Marks : 70

The Figures in the margin indicate full marks.

Candidate are required to give their answers in their own words as far as practicable

Group-A (Very Short Answer Type Question)

1. Answer any ten of the following :

[1 x 10 = 10]

- (I) The CC configuration of BJT is mainly used for _____
- (II) The maximum efficiency of a transformer coupled class A power amplifier is.....
- (III) How many stable states are there in a Monostable multivibrator?
- (IV) The value of the output impedance of an ideal op-amp is -----
- (V) The ac input to a half wave rectifier is 28.3Vpeak. Neglecting the drop across the diode, the dc across the load will be -----.
- (VI) The power amplifier that suffers mainly from the problem of crossover distortion is called -----
- (VII) State Barkhausen criteria for oscillation.
- (VIII) In a logarithmic amplifier, the logarithmic effect of the input is obtained from -----
- (IX) Half wave rectifier is an example of a diode clamper circuit. State True/False
- (X) If three cascaded stages of amplifiers have gains of 10,20,30, then what will be overall gain?
- (XI) The voltage gain without negative feedback is 40dB. What is the new voltage gain if 3% negative feedback is introduced?
- (XII) Astable multivibrator operating at 150 Hz has a discharge time of 2.5ms. Find the duty cycle of the circuit.

Group-B (Short Answer Type Question)

Answer any three of the following :

[5 x 3 = 15]

2. What are the possible classifications of power amplifiers depending on the positions of their operating point? [5]
3. Derive the expression of Time period of an Astable multivibrator. [5]
4. What is cross-over distortion? How it can be eliminated? [5]
5. Find the oscillation frequency f of the phase shift oscillator when $R = 10K\Omega$ and $C = 6.5nF$ [5]

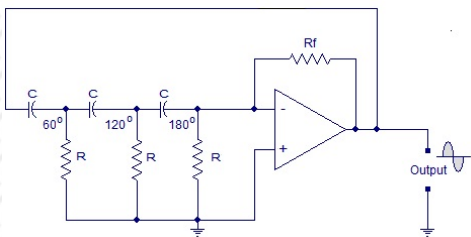

6. a) Draw the circuit diagram of the Colpitt oscillator. [5]
- b) In a Colpitt oscillator the values of the capacitors are $C_1 = 0.125\mu F$, $C_2 = 0.02\mu F$. Inductance coil $L_1 = 0.5mH$. Find i) the frequency of oscillation ii) if the frequency of oscillation is 20KHz find the value of inductance of coil iii) determine the voltage gain of the oscillator.

Group-C (Long Answer Type Question)

Answer any three of the following :

[15 x 3 = 45]

7. (a) What is rectification? A CT full wave rectifier has turns ratio of 20:1, input supply voltage of 220V and load resistance of 500Ω . Determine i) the dc output voltage ii) the rms value of load current iii) efficiency of rectifier. [1+4]
- (b) Design a clamper circuit to create a dc offset of -3V to a sine wave input of amplitude 5V also draw the output waveform. [5]

- (c) Explain the operation of the LC filter. Determine the ripple factor of a LC-type filter comprising a 10H choke and 8F capacitor used with a full wave rectifier [3+2]
8. (a) Construct the circuit diagram and the frequency response characteristics of the 2-stage RC coupled CE transistor amplifier and derive its midfrequency voltage gain. [8]
- (b) Explain the operation of a transformer-coupled Class A power amplifier. [7]
9. (a) Draw the circuit diagram of a voltage divider bias of a BJT and determine its operating point. [2+3]
- (b) What is the stability factor? Find out the expression of current stability factor for voltage divider bias configuration. [2+3]
- (c) If the various parameters of a CE amplifier in voltage divider bias method are $V_{CC}=12V$, $R_1=10K\Omega$, $R_2=5K\Omega$, $R_C=1K\Omega$, $R_E=2K\Omega$ and $\beta=100$, find the operating point and stability factor assuming the transistor is made up of Si. [5]

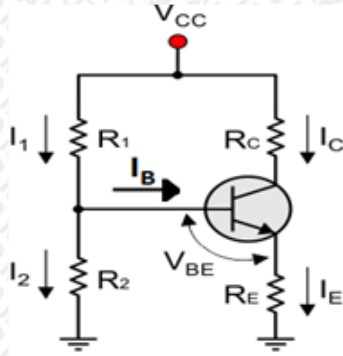

10. (a) Define the conversion efficiency of a power amplifier. Prove that the maximum conversion efficiency of a direct coupled class A power amplifier is 25%. [4+5]
- (b) Prove that the Class B push-pull power amplifier has higher efficiency than Class A amplifiers. [6]
11. (a) Explain the operation of an integrator circuit using an op-amp. [3]
- (b) Explain how it operates as a low pass filter. [3]
- (c) Write short notes on any three of the following [9]
- Integrator
 - Active filter
 - Voltage Comparator
 - Current Mirror

*** END OF PAPER ***